

# TEA152x family

SMPS ICs for low-power systems

Rev. 02 — 25 January 2006

Product data sheet

## 1. General description

---

The TEA152x family STARplug+ is a Switched Mode Power Supply (SMPS) controller IC that operates directly from the rectified universal mains. It is implemented in the high-voltage EZ-HV SOI process, combined with a low-voltage BiCMOS process. The device includes a high-voltage power switch and a circuit for start-up directly from the rectified mains voltage.

A dedicated circuit for valley switching is built in, which makes a very efficient slim-line electronic power plug concept possible.

In its most basic version of application, the TEA152x family acts as a voltage source. Here, no additional secondary electronics are required. A combined voltage and current source can be realized with minimum costs for external components. Implementation of the TEA152x family renders an efficient and low cost power supply system.

## 2. Features

---

- Designed for general purpose supplies up to 30 W
- Integrated power switch:
  - ◆ TEA1520: 48  $\Omega$ ; 650 V
  - ◆ TEA1521: 24  $\Omega$ ; 650 V
  - ◆ TEA1522: 12  $\Omega$ ; 650 V
  - ◆ TEA1523: 6.5  $\Omega$ ; 650 V
- Operates from universal AC mains supplies (80 V to 276 V)
- Adjustable frequency for flexible design
- RC oscillator for load insensitive regulation loop constant
- Valley switching for minimum switch-on loss
- Frequency reduction at low power output makes low standby power possible (< 100 mW)
- Adjustable overcurrent protection
- Undervoltage protection
- Temperature protection
- Short-circuit winding protection
- Simple application with both primary and secondary (opto) feedback
- Available in DIP8 and SO14 packages

**PHILIPS**

### 3. Applications

- Chargers
- Adapters
- Set Top Box (STB)
- DVD
- CD(R)
- TV/monitor standby supplies
- PC peripherals
- Microcontroller supplies in home applications and small portable equipment, etc.

### 4. Quick reference data

**Table 1: Quick reference data**

Symbol	Parameter	Conditions	Min	Typ	Max	Unit
$V_{\text{drain}}$	drain voltage (DMOS power transistor)	$T_j > 0\text{ °C}$	-0.4	-	+650	V
$R_{\text{DSon}}$	drain-source on-state resistance					
	TEA1520	$I_{\text{source}} = -0.06\text{ A}$				
		$T_j = 25\text{ °C}$	-	48	55.2	$\Omega$
		$T_j = 100\text{ °C}$	-	68	78.2	$\Omega$
	TEA1521	$I_{\text{source}} = -0.125\text{ A}$				
		$T_j = 25\text{ °C}$	-	24	27.6	$\Omega$
		$T_j = 100\text{ °C}$	-	34	39.1	$\Omega$
	TEA1522	$I_{\text{source}} = -0.25\text{ A}$				
		$T_j = 25\text{ °C}$	-	12	13.8	$\Omega$
		$T_j = 100\text{ °C}$	-	17	19.6	$\Omega$
	TEA1523	$I_{\text{source}} = -0.50\text{ A}$				
		$T_j = 25\text{ °C}$	-	6.5	7.5	$\Omega$
		$T_j = 100\text{ °C}$	-	9.0	10.0	$\Omega$
$V_{\text{CC}}$	supply voltage	continuous	-0.4	-	+40	V
$f_{\text{osc}}$	oscillator frequency		10	100	200	kHz
$I_{\text{drain}}$	supply current drawn from pin DRAIN	$V_{\text{drain}} > 60\text{ V}$ ; no auxiliary supply	-	1.5	2	mA
$T_{\text{amb}}$	ambient temperature		-20	-	+85	$^{\circ}\text{C}$

## 5. Ordering information

Table 2: Ordering information

Type number	Package		Version
	Name	Description	
TEA1520P	DIP8	plastic dual in-line package; 8-leads (300 mil)	SOT97-1
TEA1521P			
TEA1522P			
TEA1523P			
TEA1520T	SO14	plastic small outline package; 14-leads; body width 3.9 mm	SOT108-1
TEA1521T			
TEA1522T			

## 6. Block diagram

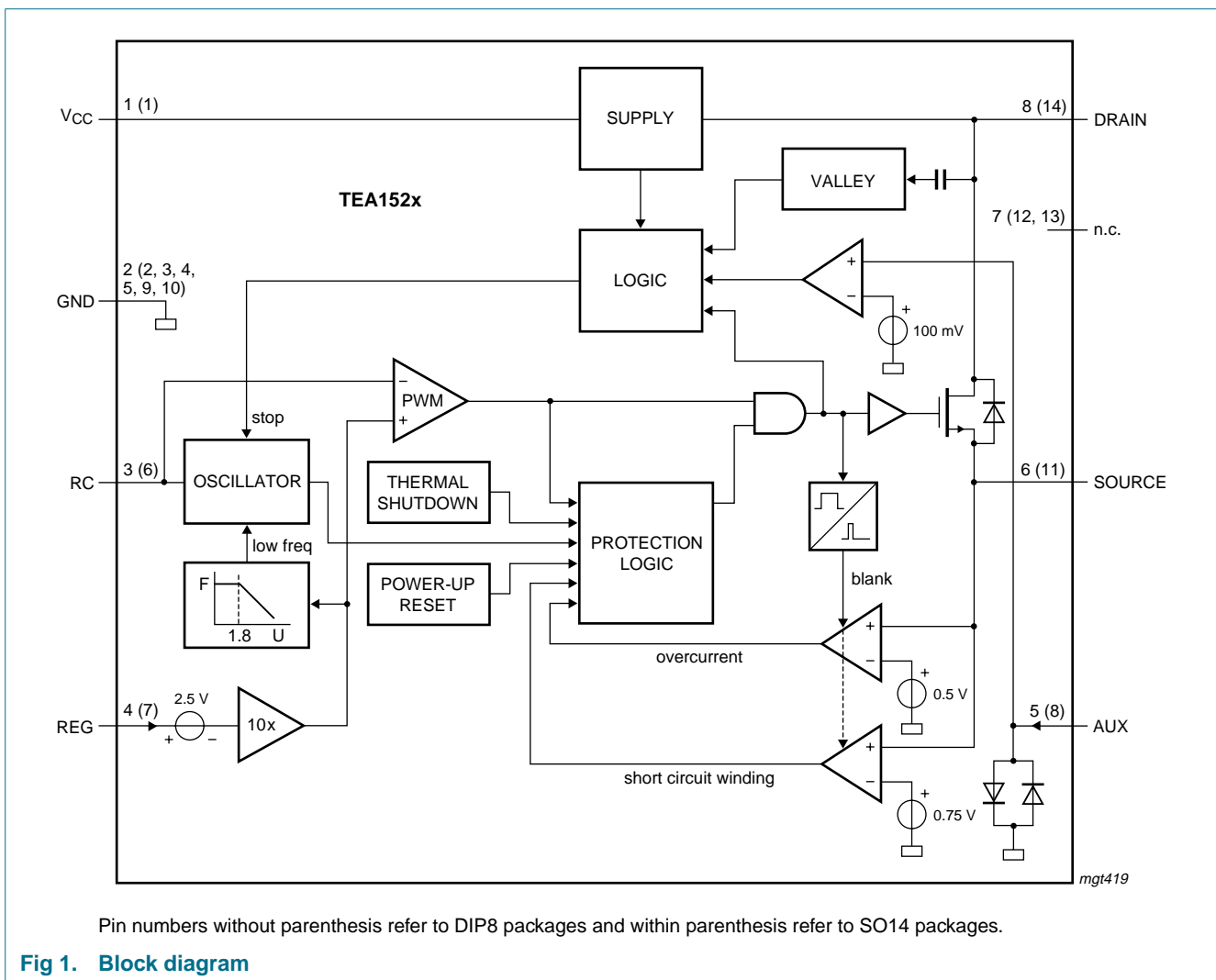

## 7. Pinning information

### 7.1 Pinning

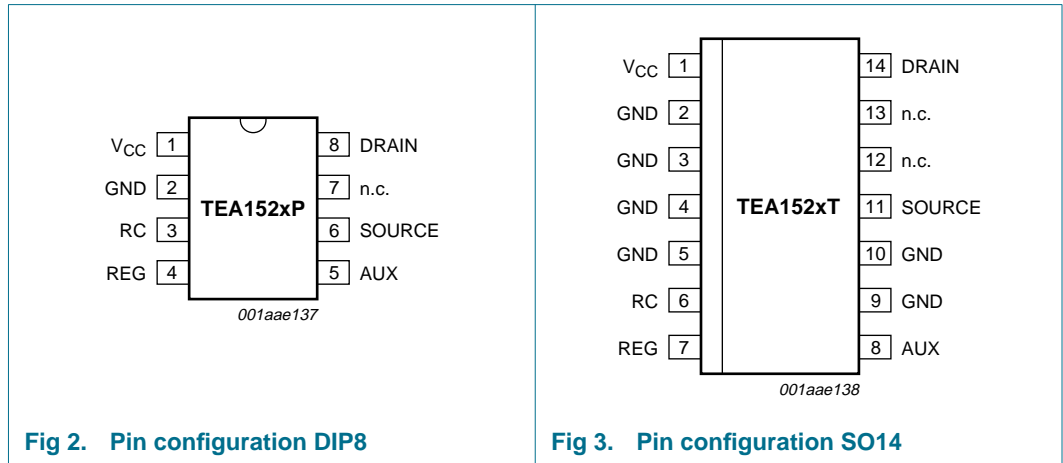

Fig 2. Pin configuration DIP8

Fig 3. Pin configuration SO14

### 7.2 Pin description

Table 3: Pin description

Symbol	Pin		Description
	DIP8	SO14	
V <sub>CC</sub>	1	1	supply voltage
GND	2	2	ground
GND	-	3	ground
GND	-	4	ground
GND	-	5	ground
RC	3	6	frequency setting
REG	4	7	regulation input
AUX	5	8	input for voltage from auxiliary winding for timing (demagnetization)
GND	-	9	ground
GND	-	10	ground
SOURCE	6	11	source of internal MOS switch
n.c.	7	12	not connected
n.c.	-	13	not connected
DRAIN	8	14	drain of internal MOS switch; input for start-up current and valley sensing

## 8. Functional description

The TEA152x family is the heart of a compact flyback converter, with the IC placed at the primary side. The auxiliary winding of the transformer can be used for indirect feedback to control the isolated output. This additional winding also powers the IC. A more accurate control of the output voltage and/or current can be implemented with an additional secondary sensing circuit and optocoupler feedback.

The TEA152x family uses voltage mode control. The frequency is determined by the maximum transformer demagnetizing time and the time of the oscillator. In the first case, the converter operates in the Self Oscillating Power Supply (SOPS) mode. In the latter case, it operates at a constant frequency, which can be adjusted with external components  $R_{RC}$  and  $C_{RC}$ . This mode is called Pulse Width Modulation (PWM). Furthermore, a primary stroke is started only in a valley of the secondary ringing. This valley switching principle minimizes capacitive switch-on losses.

### 8.1 Start-up and undervoltage lock-out

Initially, the IC is self supplying from the rectified mains voltage. The IC starts switching as soon as the voltage on pin  $V_{CC}$  passes the  $V_{CC(start)}$  level. The supply is taken over by the auxiliary winding of the transformer as soon as  $V_{CC}$  is high enough and the supply from the line is stopped for high efficiency operation.

When for some reason the auxiliary supply is not sufficient, the high-voltage supply also supplies the IC. As soon as the voltage on pin  $V_{CC}$  drops below the  $V_{CC(stop)}$  level, the IC stops switching and restarts from the rectified mains voltage.

### 8.2 Oscillator

The frequency of the oscillator is set by the external resistor and capacitor on pin RC. The external capacitor is charged rapidly to the  $V_{RC(max)}$  level and, starting from a new primary stroke, it discharges to the  $V_{RC(min)}$  level. Because the discharge is exponential, the relative sensitivity of the duty factor to the regulation voltage at low duty factor is almost equal to the sensitivity at high duty factors. This results in a more constant gain over the duty factor range compared to PWM systems with a linear sawtooth oscillator. Stable operation at low duty factors is easily realized. For high efficiency, the frequency is reduced as soon as the duty factor drops below a certain value. This is accomplished by increasing the oscillator charge time.

To ensure that the capacitor can be charged within the charge time, the value of the oscillator capacitor should be limited to approximately 1 nF.

### 8.3 Duty factor control

The duty factor is controlled by the internal regulation voltage and the oscillator signal on pin RC. The internal regulation voltage is equal to the external regulation voltage (minus 2.5 V) multiplied by the gain of the error amplifier (typically 20 dB which is 10 ×).

### 8.4 Valley switching

A new cycle is started when the primary switch is switched on (see Figure 4). After a certain time (determined by the oscillator voltage RC and the internal regulation level), the switch is turned off and the secondary stroke starts. The internal regulation level is determined by the voltage on pin REG.

After the secondary stroke, the drain voltage shows an oscillation with a frequency of approximately:

$$\frac{1}{2 \times \pi \times \sqrt{(L_p \times C_p)}} \tag{1}$$

where:

$L_p$  = primary self inductance

$C_p$  = parasitic capacitance on drain node

As soon as the oscillator voltage is high again and the secondary stroke has ended, the circuit waits for a low drain voltage before starting a new primary stroke.

Figure 4 shows the drain voltage together with the valley signal, the signal indicating the secondary stroke and the RC voltage.

The primary stroke starts some time before the actual valley at low ringing frequencies, and some time after the actual valley at high ringing frequencies.

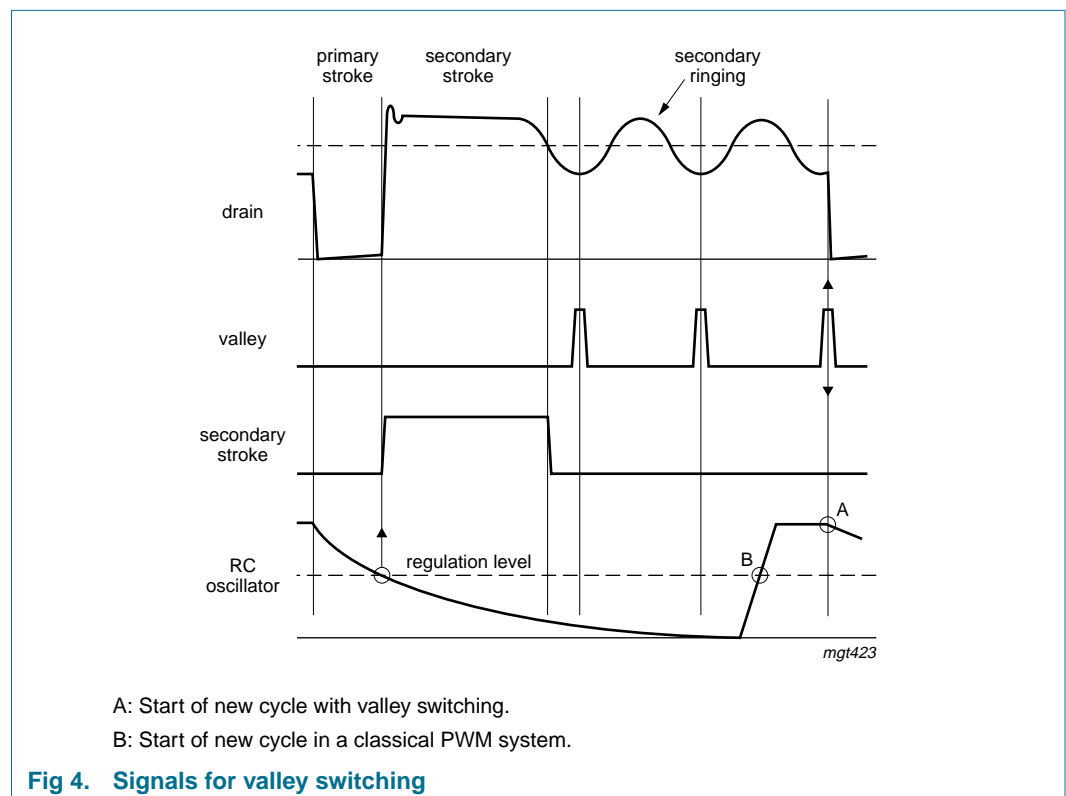

Figure 5 shows a typical curve for a reflected output voltage  $N \times V_o$  of 80 V. This voltage is the output voltage  $V_o$  (see Figure 6) transferred to the primary side of the transformer with the factor  $N$  (determined by the turns ratio of the transformer). Figure 5 shows that the system switches exactly at minimum drain voltage for ringing frequencies of 480 kHz, thus reducing the switch-on losses to a minimum. At 200 kHz, the next primary stroke is started at  $33^\circ$  before the valley. The switch-on losses are still reduced significantly.

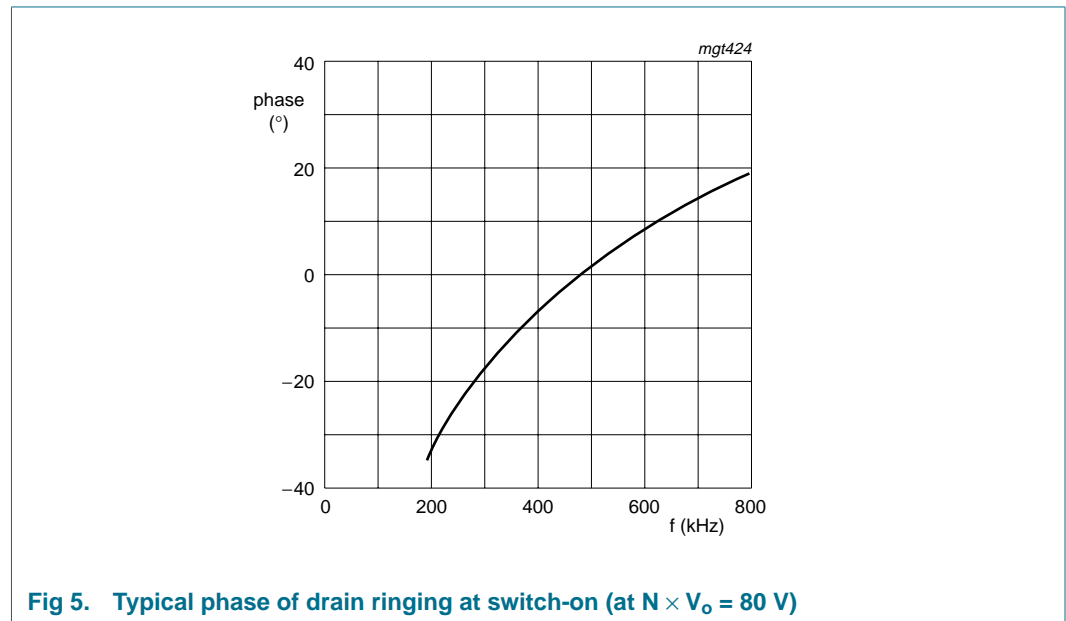

Fig 5. Typical phase of drain ringing at switch-on (at  $N \times V_o = 80$  V)

## 8.5 Demagnetization

The system operates in discontinuous conduction mode all the time. As long as the secondary stroke has not ended, the oscillator will not start a new primary stroke. During the first  $t_{\text{suppr}}$  seconds, demagnetization recognition is suppressed. This suppression may be necessary in applications where the transformer has a large leakage inductance and at low output voltages.

## 8.6 Minimum and maximum duty factor

The minimum duty factor of the switched mode power supply is 0 %. The maximum duty factor is set to 75 % (typical value at 100 kHz oscillation frequency).

## 8.7 Overcurrent protection

The cycle-by-cycle peak drain current limit circuit uses the external source resistor  $R_1$  to measure the current. The circuit is activated after the leading edge blanking time  $t_{\text{leb}}$ . The protection circuit limits the source voltage to  $V_{\text{source(max)}}$ , and thus limits the primary peak current.

## 8.8 Short-circuit winding protection

The short-circuit winding protection circuit is also activated after the leading edge blanking time. If the source voltage exceeds the short-circuit winding protection voltage  $V_{\text{swp}}$ , the IC stops switching. Only a power-on reset will restart normal operation. The short-circuit winding protection also protects in case of a secondary diode short circuit.

### 8.9 Overtemperature protection

An accurate temperature protection is provided in the device. When the junction temperature exceeds the thermal shutdown temperature, the IC stops switching. During thermal protection, the IC current is lowered to the start-up current. The IC continues normal operation as soon as the overtemperature situation has disappeared.

### 8.10 Overvoltage protection

Overvoltage protection can be achieved in the application by pulling pin REG above its normal operation level. The current primary stroke is terminated immediately, and no new primary stroke is started until the voltage on pin REG drops to its normal operation level. Pin REG has an internal clamp. The current feed into this pin must be limited.

### 8.11 Output characteristics of complete power plug

Typical characteristics:

- Output power: A wide range of output power levels can be handled by choosing the  $R_{DS(on)}$  and package of the TEA152x family. Power levels up to 30 W can be realized.
- Accuracy: The accuracy of the complete converter, functioning as a voltage source with primary sensing, is approximately 8 % (mainly dependent on the transformer coupling). The accuracy with secondary sensing is defined by the accuracy of the external components. For safety requirements in case of optocoupler feedback loss, the primary sensing remains active when an overvoltage circuit is connected.
- Efficiency: An efficiency of 75 % at maximum output power can be achieved for a complete converter designed for universal mains.
- Ripple: A minimum ripple is obtained in a system designed for a maximum duty factor of 50 % under normal operating conditions, and a minimized dead time. The magnitude of the ripple in the output voltage is determined by the frequency and duty factor of the converter, the output current level and the value and ESR of the output capacitor.

### 8.12 Input characteristics of complete power plug

Typical characteristics:

- The input voltage range comprises the universal AC mains (80 V to 276 V).



## 9. Limiting values

**Table 4: Limiting values**

In accordance with the Absolute Maximum Rating System (IEC 60134). All voltages are measured with respect to ground; positive currents flow into the device; pins  $V_{CC}$  and  $RC$  are not allowed to be current driven and pins  $REG$  and  $AUX$  are not allowed to be voltage driven.

Symbol	Parameter	Conditions	Min	Max	Unit	
<b>Voltages</b>						
$V_{CC}$	supply voltage	continuous	-0.4	+40	V	
$V_{RC}$	oscillator input voltage		-0.4	+3	V	
$V_{source}$	source voltage (DMOS power transistor)		-0.4	+5	V	
$V_{drain}$	drain voltage (DMOS power transistor)	$T_j > 0\text{ °C}$	-0.4	+650	V	
<b>Currents</b>						
$I_{REG}$	regulation input current		-	6	mA	
$I_{AUX}$	auxiliary winding input current		-10	+5	mA	
$I_{source}$	source current	TEA1520	-0.25	+0.25	A	
		TEA1521	-0.5	+0.5	A	
		TEA1522	-1	+1	A	
		TEA1523	-2	+2	A	
$I_{drain}$	drain current	TEA1520	-0.25	+0.25	A	
		TEA1521	-0.5	+0.5	A	
		TEA1522	-1	+1	A	
		TEA1523	-2	+2	A	
<b>General</b>						
$P_{tot}$	total power dissipation	DIP8 package	$T_{amb} < 45\text{ °C}$	-	1.0	W
		SO14 package	$T_{amb} < 50\text{ °C}$	-	1.0	W
$T_{stg}$	storage temperature		-55	+150	°C	
$T_{amb}$	ambient temperature		-20	+85	°C	
$T_j$	junction temperature		-20	+145	°C	
$V_{esd}$	electrostatic discharge voltage	human body model <a href="#">[1]</a>	-	±2500	V	
		machine model <a href="#">[2]</a>	-	±200	V	

[1] Human body model: equivalent to discharging a 100 pF capacitor through a 1.5 kΩ series resistor. All pins are 2500 V maximum, except pin DRAIN, which is 1000 V maximum.

[2] Machine model: equivalent to discharging a 200 pF capacitor through a 0.75 μH coil and a 10 Ω series resistor.

## 10. Thermal characteristics

**Table 5: Thermal characteristics**

Symbol	Parameter	Conditions	Typ	Unit
$R_{th(j-a)}$	thermal resistance from junction to ambient	in free air	[1]	
	DIP8 package		100	K/W
	SO14 package		91	K/W

[1] Thermal resistance  $R_{th(j-a)}$  can be lower when the GND pins are connected to sufficient copper area on the printed-circuit board. See the TEA152x application notes for details.

## 11. Characteristics

**Table 6: Characteristics**

$T_{amb} = 25\text{ }^{\circ}\text{C}$ ; no overtemperature; all voltages are measured with respect to ground; currents are positive when flowing into the IC; unless otherwise specified.

Symbol	Parameter	Conditions	Min	Typ	Max	Unit
<b>Supply</b>						
$I_{CC(operate)}$	supply current	normal operation	-	1.3	1.9	mA
$I_{CC(startup)}$	start-up supply current	start-up	-	180	400	$\mu\text{A}$
$I_{CC(ch)}$	$V_{CC}$ pin charging current	$V_{drain} > 60\text{ V}$	-6	-4	-3	mA
$V_{CC(start)}$	start voltage		9	9.5	10	V
$V_{CC(stop)}$	stop voltage	undervoltage lock-out	7.0	7.5	8.0	V
$I_{drain}$	supply current drawn from pin DRAIN	$V_{drain} > 60\text{ V}$				
		no auxiliary supply	-	1.5	2	mA
		with auxiliary supply	-	30	125	$\mu\text{A}$
<b>Pulse width modulator</b>						
$\delta_{min}$	minimum duty factor		-	0	-	%
$\delta_{max}$	maximum duty factor	$f = 100\text{ kHz}$	-	75	-	%
<b>SOPS</b>						
$V_{demag}$	demagnetization recognition voltage level		50	100	150	mV
$t_{suppr}$	suppression time of transformer ringing at start of secondary stroke		1.0	1.5	2.0	$\mu\text{s}$
<b>RC oscillator</b>						
$V_{RC(min)}$	minimum voltage of RC oscillator setting		60	75	90	mV
$V_{RC(max)}$	maximum voltage of RC oscillator setting		2.4	2.5	2.6	V
$t_{RC(ch)}$	RC charging time		-	1	-	$\mu\text{s}$
$f_{osc}$	oscillator frequency		10	100	200	kHz
<b>Duty factor regulator: pin REG</b>						
$V_{REG}$	input voltage		2.4	2.5	2.6	V
$G_{V(erroramp)}$	voltage gain of error amplifier		-	20	-	dB

**Table 6: Characteristics ...continued**

$T_{amb} = 25\text{ °C}$ ; no overtemperature; all voltages are measured with respect to ground; currents are positive when flowing into the IC; unless otherwise specified.

Symbol	Parameter	Conditions	Min	Typ	Max	Unit
$V_{REG(clamp)}$	clamping voltage at pin REG	$I_{REG} = 6\text{ mA}$	-	-	7.5	V
<b>Valley switching</b>						
$dV/dt_{valley}$	$dV/dt$ for valley recognition		-102	-	+102	V/ $\mu$ s
$f_{valley}$	ringing frequency for valley switching	$N \times V_o = 100\text{ V}$	200	550	800	kHz
$t_{d(valley-swon)}$	delay from valley recognition to switch-on		-	150	-	ns
<b>Current and short-circuit winding protection</b>						
$V_{source(max)}$	maximum source voltage	$dV/dt = 0.1\text{ V}/\mu\text{s}$	0.47	0.50	0.53	V
$t_{d(prop)}$	delay from detecting $V_{source(max)}$ to switch-off	$dV/dt = 0.5\text{ V}/\mu\text{s}$	-	160	185	ns
$V_{swp}$	short circuit winding protection voltage	$dV/dt = 0.5\text{ V}/\mu\text{s}$	0.7	0.75	0.8	V
$t_{leb}$	leading edge blanking time		250	350	450	ns
<b>FET output stage</b>						
$I_{L(drain)}$	drain leakage current	$V_{drain} = 650\text{ V}$	-	-	125	$\mu$ A
$V_{(BR)drain}$	drain breakdown voltage	$T_j > 0\text{ °C}$	650	-	-	V
$R_{DSon}$	drain-source on-state resistance					
	TEA1520	$I_{source} = -0.06\text{ A}$				
		$T_j = 25\text{ °C}$	-	48	55.2	$\Omega$
		$T_j = 100\text{ °C}$	-	68	78.2	$\Omega$
	TEA1521	$I_{source} = -0.125\text{ A}$				
		$T_j = 25\text{ °C}$	-	24	27.6	$\Omega$
		$T_j = 100\text{ °C}$	-	34	39.1	$\Omega$
	TEA1522	$I_{source} = -0.25\text{ A}$				
		$T_j = 25\text{ °C}$	-	12	13.8	$\Omega$
		$T_j = 100\text{ °C}$	-	17	19.6	$\Omega$
	TEA1523	$I_{source} = -0.50\text{ A}$				
		$T_j = 25\text{ °C}$	-	6.5	7.5	$\Omega$
		$T_j = 100\text{ °C}$	-	9.0	10.0	$\Omega$
$t_{drain(f)}$	drain fall time	$V_i = 300\text{ V}$ ; no external capacitor at drain	-	75	-	ns
<b>Temperature protection</b>						
$T_{prot(max)}$	maximum threshold temperature		150	160	170	$^{\circ}\text{C}$
$T_{prot(hys)}$	hysteresis temperature		-	2	-	$^{\circ}\text{C}$

## 12. Application information

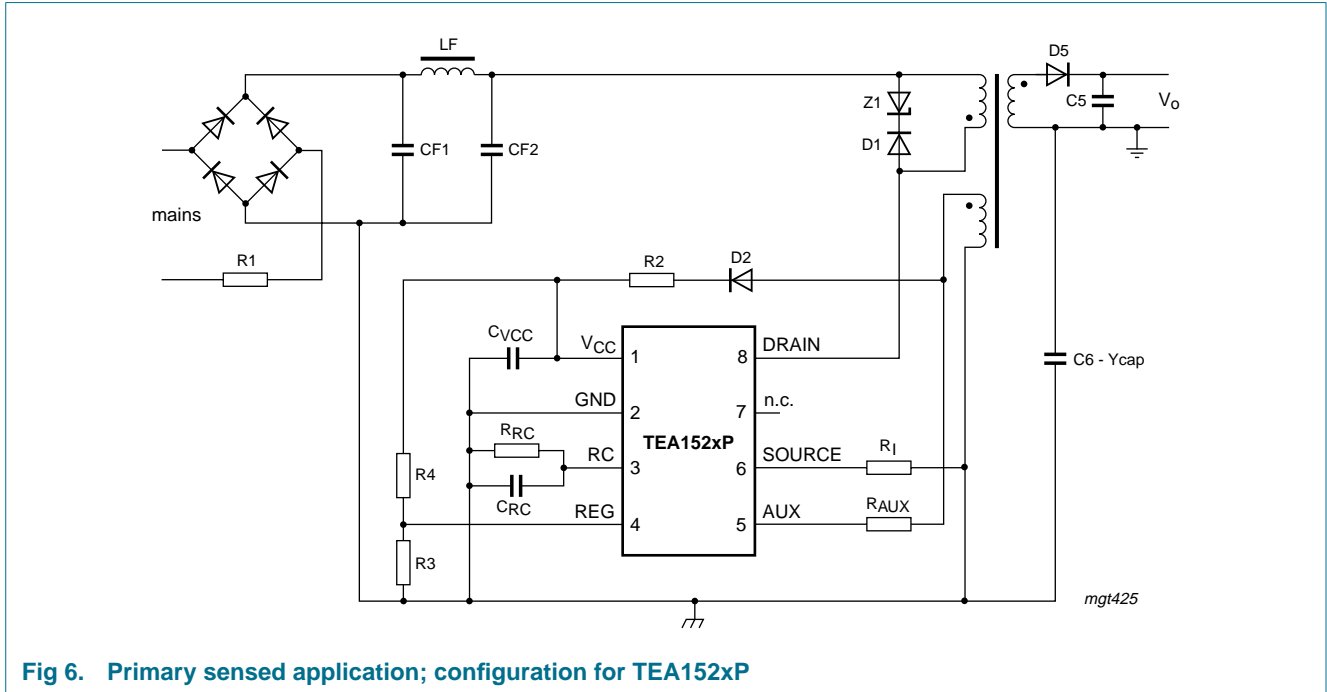

Fig 6. Primary sensed application; configuration for TEA152xP

Further application information can be found in the TEA152x application notes.

## 13. Test information

### 13.1 Quality information

The *General Quality Specification for Integrated Circuits, SNW-FQ-611* is applicable.

14. Package outline

DIP8: plastic dual in-line package; 8 leads (300 mil)

SOT97-1

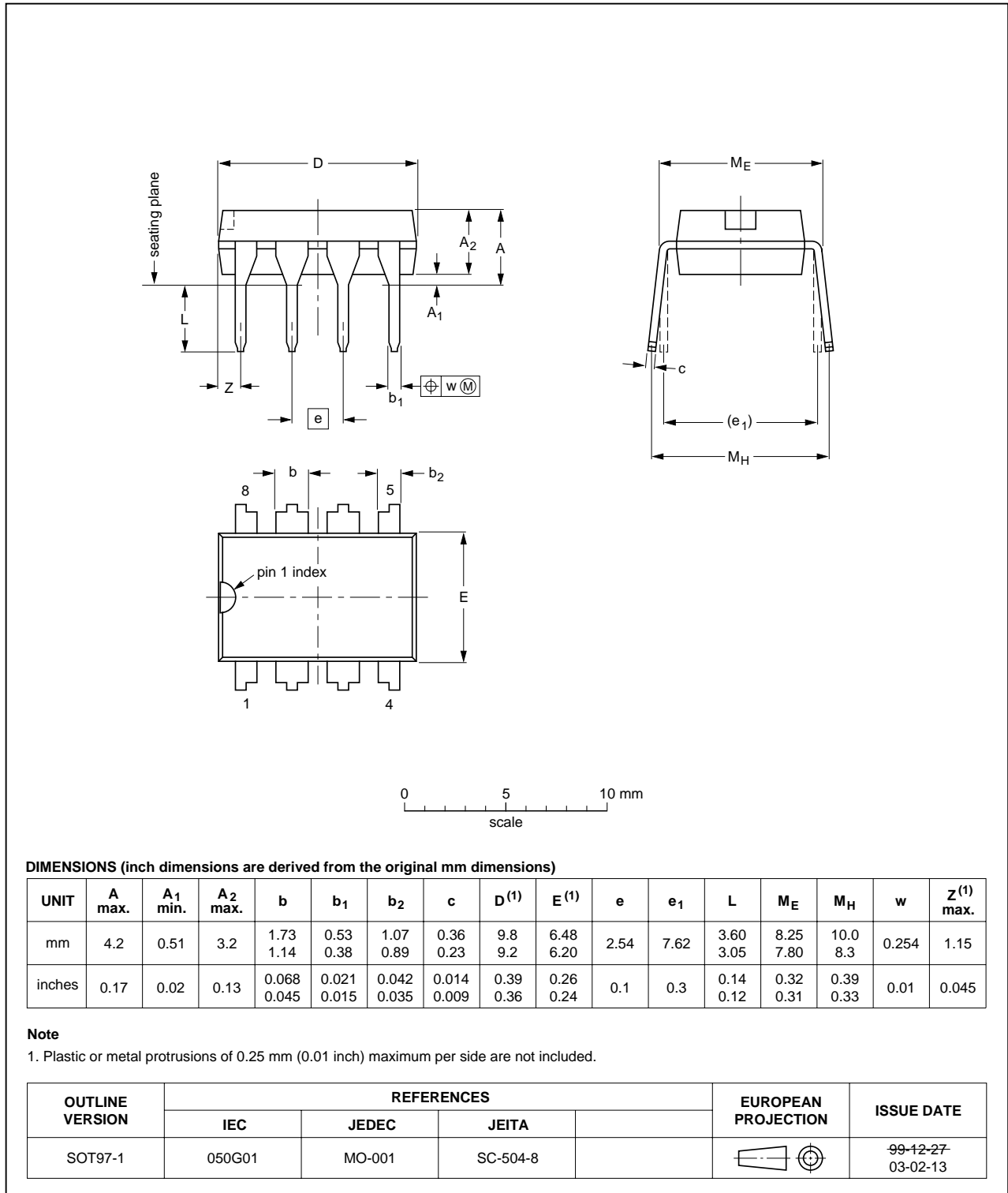

Fig 7. Package outline SOT97-1 (DIP8)

SO14: plastic small outline package; 14 leads; body width 3.9 mm

SOT108-1

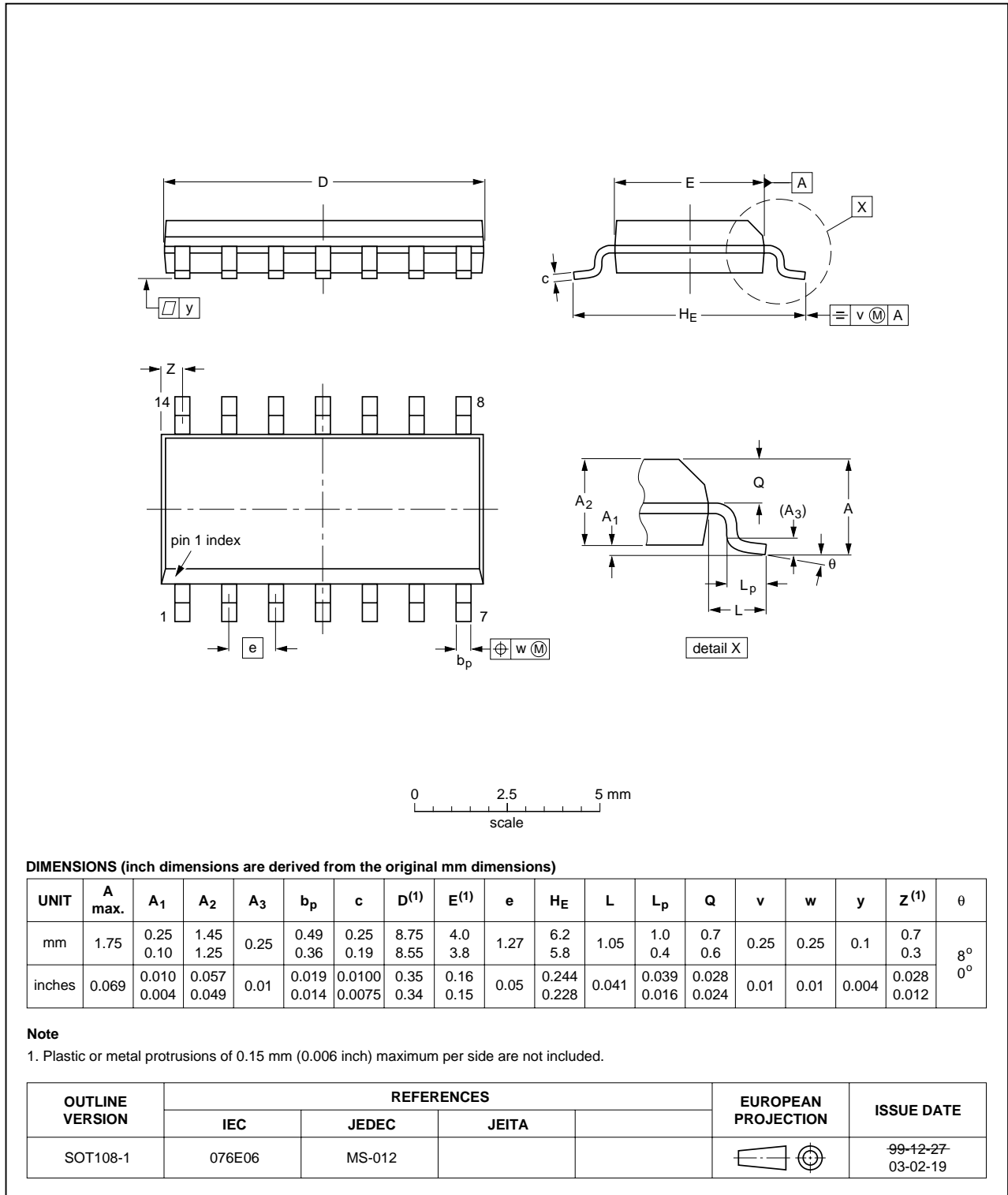

Fig 8. Package outline SOT108-1 (SO14)

## 15. Handling information

---

Inputs and outputs are protected against electrostatic discharge in normal handling. However, to be completely safe you must take normal precautions appropriate to handling integrated circuits.

## 16. Soldering

---

### 16.1 Introduction

This text gives a very brief insight to a complex technology. A more in-depth account of soldering ICs can be found in our *Data Handbook IC26; Integrated Circuit Packages* (document order number 9398 652 90011).

There is no soldering method that is ideal for all IC packages. Wave soldering is often preferred when through-hole and surface mount components are mixed on one printed-circuit board. Wave soldering can still be used for certain surface mount ICs, but it is not suitable for fine pitch SMDs. In these situations reflow soldering is recommended.

Driven by legislation and environmental forces the worldwide use of lead-free solder pastes is increasing.

### 16.2 Through-hole mount packages

#### 16.2.1 Soldering by dipping or by solder wave

Typical dwell time of the leads in the wave ranges from 3 seconds to 4 seconds at 250 °C or 265 °C, depending on solder material applied, SnPb or Pb-free respectively.

The total contact time of successive solder waves must not exceed 5 seconds.

The device may be mounted up to the seating plane, but the temperature of the plastic body must not exceed the specified maximum storage temperature ( $T_{stg(max)}$ ). If the printed-circuit board has been pre-heated, forced cooling may be necessary immediately after soldering to keep the temperature within the permissible limit.

#### 16.2.2 Manual soldering

Apply the soldering iron (24 V or less) to the lead(s) of the package, either below the seating plane or not more than 2 mm above it. If the temperature of the soldering iron bit is less than 300 °C it may remain in contact for up to 10 seconds. If the bit temperature is between 300 °C and 400 °C, contact may be up to 5 seconds.

### 16.3 Surface mount packages

#### 16.3.1 Reflow soldering

Reflow soldering requires solder paste (a suspension of fine solder particles, flux and binding agent) to be applied to the printed-circuit board by screen printing, stencilling or pressure-syringe dispensing before package placement.

Several methods exist for reflowing; for example, convection or convection/infrared heating in a conveyor type oven. Throughput times (preheating, soldering and cooling) vary between 100 seconds and 200 seconds depending on heating method.

Typical reflow peak temperatures range from 215 °C to 270 °C depending on solder paste material. The top-surface temperature of the packages should preferably be kept:

- below 225 °C (SnPb process) or below 245 °C (Pb-free process)
  - for all BGA, HTSSON..T and SSOP..T packages
  - for packages with a thickness  $\geq 2.5$  mm
  - for packages with a thickness  $< 2.5$  mm and a volume  $\geq 350$  mm<sup>3</sup> so called thick/large packages.
- below 240 °C (SnPb process) or below 260 °C (Pb-free process) for packages with a thickness  $< 2.5$  mm and a volume  $< 350$  mm<sup>3</sup> so called small/thin packages.

Moisture sensitivity precautions, as indicated on packing, must be respected at all times.

### 16.3.2 Wave soldering

Conventional single wave soldering is not recommended for surface mount devices (SMDs) or printed-circuit boards with a high component density, as solder bridging and non-wetting can present major problems.

To overcome these problems the double-wave soldering method was specifically developed.

If wave soldering is used the following conditions must be observed for optimal results:

- Use a double-wave soldering method comprising a turbulent wave with high upward pressure followed by a smooth laminar wave.
- For packages with leads on two sides and a pitch (e):
  - larger than or equal to 1.27 mm, the footprint longitudinal axis is **preferred** to be parallel to the transport direction of the printed-circuit board;
  - smaller than 1.27 mm, the footprint longitudinal axis **must** be parallel to the transport direction of the printed-circuit board.

The footprint must incorporate solder thieves at the downstream end.

- For packages with leads on four sides, the footprint must be placed at a 45° angle to the transport direction of the printed-circuit board. The footprint must incorporate solder thieves downstream and at the side corners.

During placement and before soldering, the package must be fixed with a droplet of adhesive. The adhesive can be applied by screen printing, pin transfer or syringe dispensing. The package can be soldered after the adhesive is cured.

Typical dwell time of the leads in the wave ranges from 3 seconds to 4 seconds at 250 °C or 265 °C, depending on solder material applied, SnPb or Pb-free respectively.

A mildly-activated flux will eliminate the need for removal of corrosive residues in most applications.



### 16.3.3 Manual soldering

Fix the component by first soldering two diagonally-opposite end leads. Use a low voltage (24 V or less) soldering iron applied to the flat part of the lead. Contact time must be limited to 10 seconds at up to 300 °C.

When using a dedicated tool, all other leads can be soldered in one operation within 2 seconds to 5 seconds between 270 °C and 320 °C.

## 16.4 Package related soldering information

Table 7: Suitability of IC packages for wave, reflow and dipping soldering methods

Mounting	Package [1]	Soldering method		
		Wave	Reflow [2]	Dipping
Through-hole mount	CPGA, HCPGA	suitable	–	–
	DBS, DIP, HDIP, RDBS, SDIP, SIL	suitable [3]	–	suitable
Through-hole-surface mount	PMFP [4]	not suitable	not suitable	–
Surface mount	BGA, HTSSON..T [5], LBGGA, LFBGA, SQFP, SSOP..T [5], TFBGA, VFBGA, XSON	not suitable	suitable	–
	DHVQFN, HBCC, HBGA, HLQFP, HSO, HSOP, HSQFP, HSSON, HTQFP, HTSSOP, HVQFN, HVSON, SMS	not suitable [6]	suitable	–
	PLCC [7], SO, SOJ	suitable	suitable	–
	LQFP, QFP, TQFP	not recommended [7] [8]	suitable	–
	SSOP, TSSOP, VSO, VSSOP	not recommended [9]	suitable	–
	CWQCCN..L [10], WQCCN..L [10]	not suitable	not suitable	–

- [1] For more detailed information on the BGA packages refer to the *(LF)BGA Application Note (AN01026)*; order a copy from your Philips Semiconductors sales office.
- [2] All surface mount (SMD) packages are moisture sensitive. Depending upon the moisture content, the maximum temperature (with respect to time) and body size of the package, there is a risk that internal or external package cracks may occur due to vaporization of the moisture in them (the so called popcorn effect). For details, refer to the Drypack information in the *Data Handbook IC26; Integrated Circuit Packages; Section: Packing Methods*.
- [3] For SDIP packages, the longitudinal axis must be parallel to the transport direction of the printed-circuit board.
- [4] Hot bar soldering or manual soldering is suitable for PMFP packages.
- [5] These transparent plastic packages are extremely sensitive to reflow soldering conditions and must on no account be processed through more than one soldering cycle or subjected to infrared reflow soldering with peak temperature exceeding 217 °C ± 10 °C measured in the atmosphere of the reflow oven. The package body peak temperature must be kept as low as possible.
- [6] These packages are not suitable for wave soldering. On versions with the heatsink on the bottom side, the solder cannot penetrate between the printed-circuit board and the heatsink. On versions with the heatsink on the top side, the solder might be deposited on the heatsink surface.
- [7] If wave soldering is considered, then the package must be placed at a 45° angle to the solder wave direction. The package footprint must incorporate solder thieves downstream and at the side corners.
- [8] Wave soldering is suitable for LQFP, QFP and TQFP packages with a pitch (e) larger than 0.8 mm; it is definitely not suitable for packages with a pitch (e) equal to or smaller than 0.65 mm.
- [9] Wave soldering is suitable for SSOP, TSSOP, VSO and VSSOP packages with a pitch (e) equal to or larger than 0.65 mm; it is definitely not suitable for packages with a pitch (e) equal to or smaller than 0.5 mm.
- [10] Image sensor packages in principle should not be soldered. They are mounted in sockets or delivered pre-mounted on flex foil. However, the image sensor package can be mounted by the client on a flex foil by using a hot bar soldering process. The appropriate soldering profile can be provided on request.

## 17. Abbreviations

**Table 8: Abbreviations**

Acronym	Description
BiCMOS	Bipolar Complementary Metal Oxide Semiconductor
DMOS	Diffusion Metal-Oxide Semiconductor
ESR	Equivalent Series Resistance
EZ-HV SOI	Easy High Voltage Silicon-On-Insulator
FET	Field-Effect Transistor
PWM	Pulse Width Modulation
SMPS	Switched Mode Power Supply
SOPS	Self Oscillating Power Supply

## 18. Revision history

**Table 9: Revision history**

Document ID	Release date	Data sheet status	Change notice	Doc. number	Supersedes
TEA152X_FAM_2	20060125	Product data sheet	-	-	TEA152X_FAMILY_1
Modifications:	<ul style="list-style-type: none"> <li>The format of this data sheet has been redesigned to comply with the new presentation and information standard of Philips Semiconductors.</li> <li>Deleted type number TEA1524</li> <li>Deleted DBS9P packages</li> <li><a href="#">Section 2</a> and <a href="#">Section 8.11</a>: Power level of 50 W changed in 30 W</li> </ul>				
TEA152X_FAMILY_1	20000908	Product specification	-	-	-

## 19. Data sheet status

Level	Data sheet status <sup>[1]</sup>	Product status <sup>[2] [3]</sup>	Definition
I	Objective data	Development	This data sheet contains data from the objective specification for product development. Philips Semiconductors reserves the right to change the specification in any manner without notice.
II	Preliminary data	Qualification	This data sheet contains data from the preliminary specification. Supplementary data will be published at a later date. Philips Semiconductors reserves the right to change the specification without notice, in order to improve the design and supply the best possible product.
III	Product data	Production	This data sheet contains data from the product specification. Philips Semiconductors reserves the right to make changes at any time in order to improve the design, manufacturing and supply. Relevant changes will be communicated via a Customer Product/Process Change Notification (CPCN).

[1] Please consult the most recently issued data sheet before initiating or completing a design.

[2] The product status of the device(s) described in this data sheet may have changed since this data sheet was published. The latest information is available on the Internet at URL <http://www.semiconductors.philips.com>.

[3] For data sheets describing multiple type numbers, the highest-level product status determines the data sheet status.

## 20. Definitions

**Short-form specification** — The data in a short-form specification is extracted from a full data sheet with the same type number and title. For detailed information see the relevant data sheet or data handbook.

**Limiting values definition** — Limiting values given are in accordance with the Absolute Maximum Rating System (IEC 60134). Stress above one or more of the limiting values may cause permanent damage to the device. These are stress ratings only and operation of the device at these or at any other conditions above those given in the Characteristics sections of the specification is not implied. Exposure to limiting values for extended periods may affect device reliability.

**Application information** — Applications that are described herein for any of these products are for illustrative purposes only. Philips Semiconductors makes no representation or warranty that such applications will be suitable for the specified use without further testing or modification.

## 21. Disclaimers

**Life support** — These products are not designed for use in life support appliances, devices, or systems where malfunction of these products can reasonably be expected to result in personal injury. Philips Semiconductors

## 23. Contact information

For additional information, please visit: <http://www.semiconductors.philips.com>

For sales office addresses, send an email to: [sales.addresses@www.semiconductors.philips.com](mailto:sales.addresses@www.semiconductors.philips.com)

customers using or selling these products for use in such applications do so at their own risk and agree to fully indemnify Philips Semiconductors for any damages resulting from such application.

**Right to make changes** — Philips Semiconductors reserves the right to make changes in the products - including circuits, standard cells, and/or software - described or contained herein in order to improve design and/or performance. When the product is in full production (status 'Production'), relevant changes will be communicated via a Customer Product/Process Change Notification (CPCN). Philips Semiconductors assumes no responsibility or liability for the use of any of these products, conveys no license or title under any patent, copyright, or mask work right to these products, and makes no representations or warranties that these products are free from patent, copyright, or mask work right infringement, unless otherwise specified.

## 22. Trademarks

**Notice** — All referenced brands, product names, service names and trademarks are the property of their respective owners.

**STARplug+** — is a trademark of Koninklijke Philips Electronics N.V.

**EZ-HV** — is a trademark of Koninklijke Philips Electronics N.V.

## 24. Contents

<b>1</b>	<b>General description</b> .....	<b>1</b>	<b>21</b>	<b>Disclaimers</b> .....	<b>19</b>
<b>2</b>	<b>Features</b> .....	<b>1</b>	<b>22</b>	<b>Trademarks</b> .....	<b>19</b>
<b>3</b>	<b>Applications</b> .....	<b>2</b>	<b>23</b>	<b>Contact information</b> .....	<b>19</b>
<b>4</b>	<b>Quick reference data</b> .....	<b>2</b>			
<b>5</b>	<b>Ordering information</b> .....	<b>3</b>			
<b>6</b>	<b>Block diagram</b> .....	<b>3</b>			
<b>7</b>	<b>Pinning information</b> .....	<b>4</b>			
7.1	Pinning .....	4			
7.2	Pin description .....	4			
<b>8</b>	<b>Functional description</b> .....	<b>5</b>			
8.1	Start-up and undervoltage lock-out .....	5			
8.2	Oscillator .....	5			
8.3	Duty factor control .....	5			
8.4	Valley switching .....	6			
8.5	Demagnetization .....	7			
8.6	Minimum and maximum duty factor .....	7			
8.7	Overcurrent protection .....	7			
8.8	Short-circuit winding protection .....	7			
8.9	Overtemperature protection .....	8			
8.10	Overvoltage protection .....	8			
8.11	Output characteristics of complete power plug ..	8			
8.12	Input characteristics of complete power plug ..	8			
<b>9</b>	<b>Limiting values</b> .....	<b>9</b>			
<b>10</b>	<b>Thermal characteristics</b> .....	<b>10</b>			
<b>11</b>	<b>Characteristics</b> .....	<b>10</b>			
<b>12</b>	<b>Application information</b> .....	<b>12</b>			
<b>13</b>	<b>Test information</b> .....	<b>12</b>			
13.1	Quality information .....	12			
<b>14</b>	<b>Package outline</b> .....	<b>13</b>			
<b>15</b>	<b>Handling information</b> .....	<b>15</b>			
<b>16</b>	<b>Soldering</b> .....	<b>15</b>			
16.1	Introduction .....	15			
16.2	Through-hole mount packages .....	15			
16.2.1	Soldering by dipping or by solder wave .....	15			
16.2.2	Manual soldering .....	15			
16.3	Surface mount packages .....	15			
16.3.1	Reflow soldering .....	15			
16.3.2	Wave soldering .....	16			
16.3.3	Manual soldering .....	17			
16.4	Package related soldering information .....	17			
<b>17</b>	<b>Abbreviations</b> .....	<b>18</b>			
<b>18</b>	<b>Revision history</b> .....	<b>18</b>			
<b>19</b>	<b>Data sheet status</b> .....	<b>19</b>			
<b>20</b>	<b>Definitions</b> .....	<b>19</b>			



© Koninklijke Philips Electronics N.V. 2006

All rights are reserved. Reproduction in whole or in part is prohibited without the prior written consent of the copyright owner. The information presented in this document does not form part of any quotation or contract, is believed to be accurate and reliable and may be changed without notice. No liability will be accepted by the publisher for any consequence of its use. Publication thereof does not convey nor imply any license under patent- or other industrial or intellectual property rights.

Date of release: 25 January 2006  
Document number: TEA152X\_FAM\_2

Published in The Netherlands